

EI19-02 Series

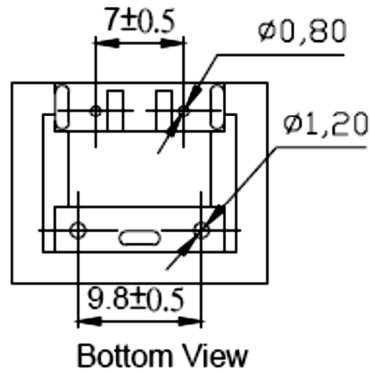

Test Circuit:

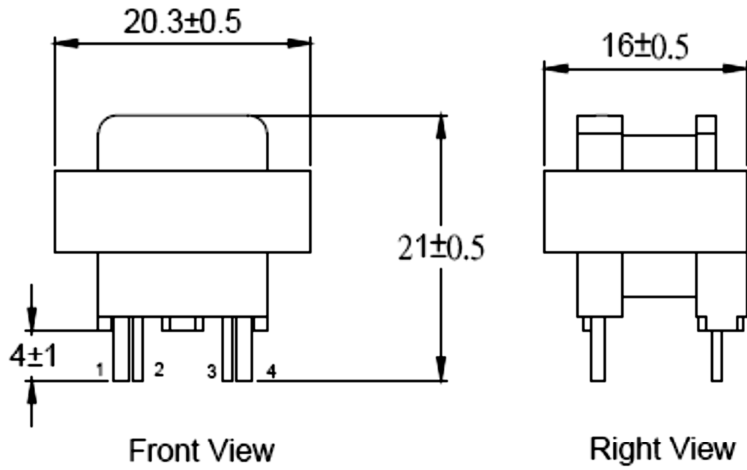
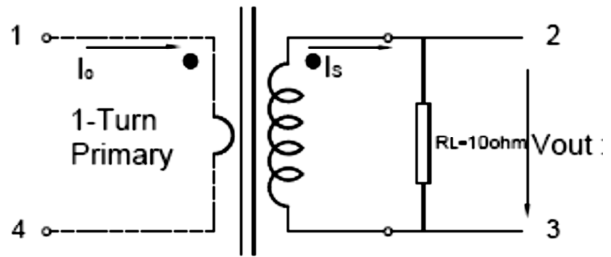

Electrical Characteristic						Mechanical Dimension		
Part Number	IR (A)	Vout (V)	Acc.Class (%)	RL (Ω)	DCR (Ω)	L(max)	W(max)	H(max)
						(mm/inch)		
EI19-02-100-3-05	5	0.471	10	10	100	<u>20.3</u> 7.99	<u>16.0</u> 6.30	<u>21.0</u> 8.27
EI19-02-150-3-05	5	0.317	10	10	280			
EI19-02-220-3-05	5	0.216	10	10	485			
EI19-02-300-3-10	10	0.321	5	10	695			