

HCOL01 Series

For the electronic measurement of currents : DC, AC, pulsed, mixed,
with a galvanic isolation between the primary (high power)
circuit and the secondary (electronic) circuit.



Operating performance (AT =25 °C)

Part No.		HCOL01-050-11	HCOL01-100-11	HCOL01-120-11	HCOL01-150-11	HCOL01-200-11	HCOL01-250-11	HCOL01-500-11
Primary nominal r.m.s. current	I_{PN} (A)	5	10	12.5	15	20	25	50
Primary current measuring range	I_P (A)	0~±15	0~±30	0~±37.5	0~±45	0~±60	0~±75	0~±150
Supply voltage	V_{CC}	±15 V (±5%)						
Output voltage	V_{OUT}	4 V±1% @± I_{PN} , $R_L = 10K\Omega$						
Current consumption	I_C	±10mA @ ± I_{PN}						
Offset voltage	V_O	< ±0.03V @ $I_P=0, T_A=25^\circ C$						
Thermal drift of V_O	V_{OT}	≤ ±1.5mV/°C						
Thermal drift of V_{OUT}	$TC\epsilon_G$	< ±0.1%/°C						
Response time	t_r	< 3µs						
Linearity	ϵ_L	≤ ±1% @0~± I_{PN}						
Accuracy	X	±1% @ I_{PN}						
Hysteresis offset voltage	V_{OH}	≤ ±20mV @±3 $I_{PN} \rightarrow 0$						
Isolation voltage	V_d	2.5KV @50(60)Hz/1min						
Frequency bandwidth	f	0~50KHz						

General data

Operating temperature	T_A	-25 ~ 80°C
Storage temperature	T_S	-40 ~ 85°C
Mass	m	17g
Note		Insulated plastic case recognized according to UL 94-V 0

Applications

1.AC variable speed drives and servo motor drives	4.Static converters for DC motor drives
2.Battery supplied applications	5.Switched Mode Power Supplies(SMPS)
3.Uninterruptible Power Supplies(UPS)	6.Power supplies for welding applications

Advantages

1.No insertion losses	4.Optimized response time
2.Easy to mount with automatic handling system	5.High immunity to external interference
3.Small size and space saving	6.Only one desing for wide curretn ratings range

HCOL01 Series

Connection

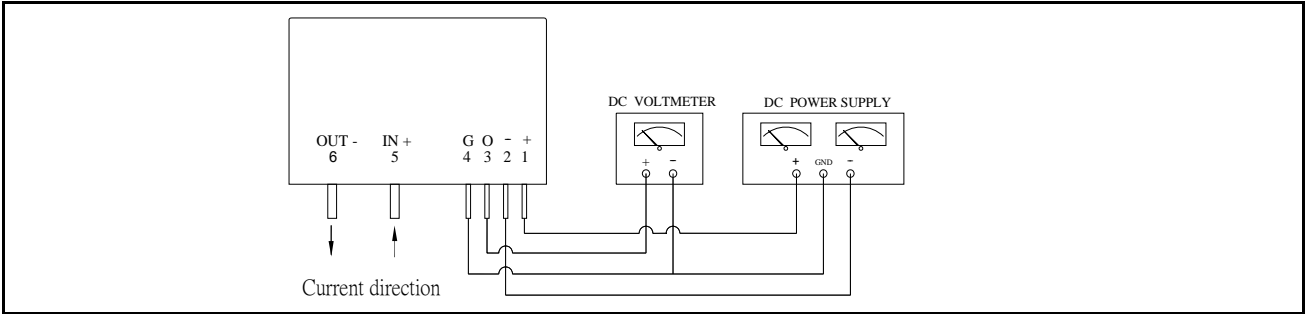

Dimensions (unit: mm/inch)

